

---

# Image formation in fundus cameras

Oleg Pomerantzeff, Robert H. Webb, and Francois C. Delori

*Imaging in a fundus camera depends more on design of the system stop than on correction of the first fundus image as formed by the ophthalmoscopic lens. We show here that the designer may use the free parameters of the ophthalmoscopic lens (contact or noncontact) to correct the latter for observation and illumination of the fundus. In both contact and noncontact systems the fundus is illuminated by forming a ring of light on the patient's cornea around a central area (the corneal window) reserved for observation. On the first surface of the crystalline lens, the light also forms a ring which must accommodate the total entrance pupil (TEP) of the observation system in its middle and which is limited on the outside by the patient's iris. The restrictions that result from this situation define the entrance pupil of the bundle of rays that image the marginal point of the retina. The limits of this bundle are imposed by the choice of the angular field of view and by the size of the patient's pupil.*

**Key words:** fundus camera, ophthalmoscopic, wide-field, image formation, camera stop

**F**undus photography differs from conventional photography in that the object to be photographed is a virtual image of the retina (at infinity for all angles in an emmetropic eye). The optics of the fundus camera consist therefore of two systems. (1) The ophthalmoscopic lens (the first lens) forms a real aerial image of the fundus. In wide-field fundus cameras this lens is in contact with the cornea and is followed by a field lens which may have multiple elements. (2) Following these two lenses is the actual camera, usually a commercial (nonspecialized) system that reimages the intermediate aerial image and records it on film.

It follows that the only information that can be recorded on the film is that contained in

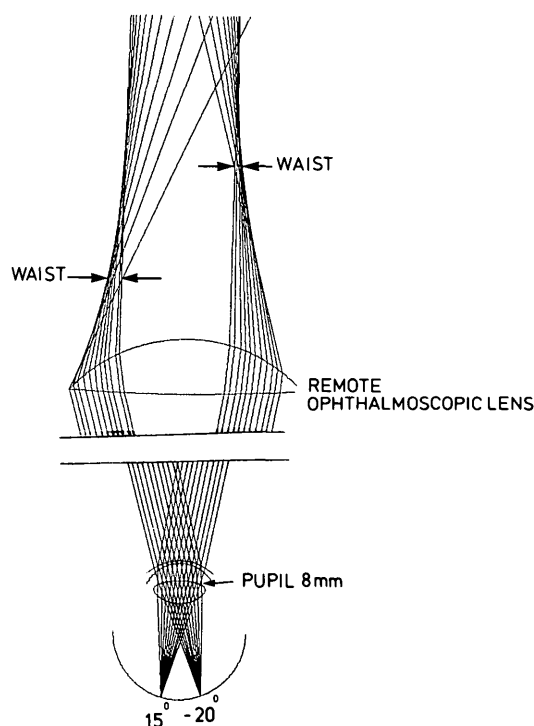

**Fig. 1.** Noncontact system. Bundles of rays originating in different points of the retina and limited by a large (8 mm) pupil do not come to a focus. They present large waists that cannot be considered as images.

---

From the Department of Retina Research, Eye Research Institute of Retina Foundation, Boston, Mass.

Supported in part by National Eye Institute grant EY 01975-02, Research to Prevent Blindness, Inc., and the Massachusetts Lions Eye Research Fund, Inc.

Submitted for publication Aug. 14, 1978.

Reprint requests: Library, Eye Research Institute of Retina Foundation, 20 Staniford St., Boston, Mass. 02114.

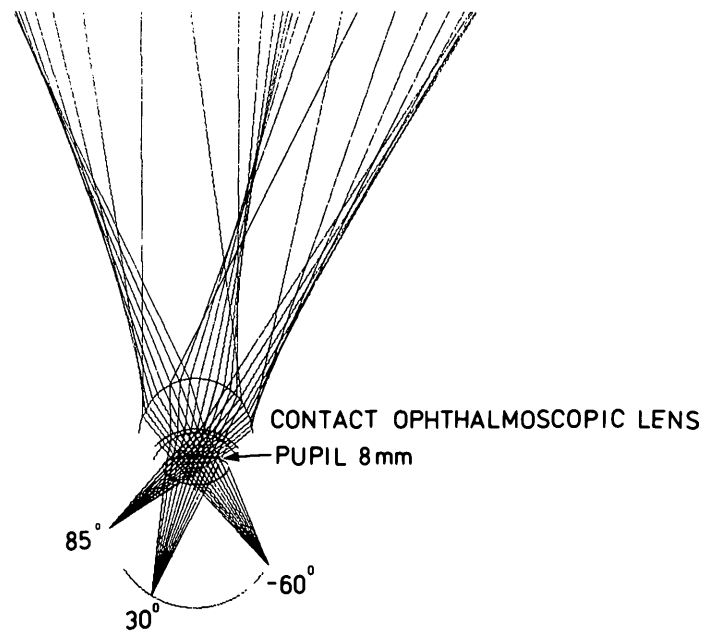

Fig. 2. Contact system. Same situation as described in Fig. 1.

the aerial image formed by the ophthalmoscopic lens. So the designer's first inclination is to correct the ophthalmoscopic lens in order to achieve the best image of the fundus.

On the other hand, Gullstrand<sup>1</sup> has pointed out that in ophthalmoscopy, the ray bundles used for illumination and observation should be separated on the cornea and on the first surface of the crystalline lens. This can be achieved with the use of the free parameters of the ophthalmoscopic lens, but not if these have already been used for improving the fundus image. It is therefore of prime importance to choose between these two alternatives.

It is the purpose of this report to show that in fundus photography, as well as in ophthalmoscopy, it is not essential to correct the ophthalmoscopic lens for the aerial image of the fundus. Thus the free parameters of the ophthalmoscopic lens can be used for separation of the observation and illumination bundles on the most reflecting surfaces of the eye: the cornea and the first surface of the crystalline lens.

Another problem in fundus photography arises from the very strong curvature of the

retina. This problem increases with the field angle and becomes severe in the equator-plus camera (EPC), a wide-angle camera in which the field angle extends beyond the equator.<sup>2, 3</sup> It will be shown, however, that because of the peculiarities of image formation in the optical system of a fundus camera, it is possible to focus the whole retina on a plane, maintaining the same image quality in the posterior pole as in the periphery.

Two surfaces in the eye, the cornea and the anterior surface of the crystalline lens, generate deleterious reflections. To prevent these reflections from entering the recording camera, we have applied the Gullstrand separation principle, which requires that different areas be reserved for observation and illumination on both surfaces. This requirement imposes a constraint on the size of these areas, which in turn has bearing on the patient's pupil dilation and the observable field size.

#### Ophthalmoscopic lens

For all the following computations we have used the wide-angle mathematical model of the eye designed in this laboratory.<sup>4, 5</sup>

An ophthalmoscopic lens that is placed in

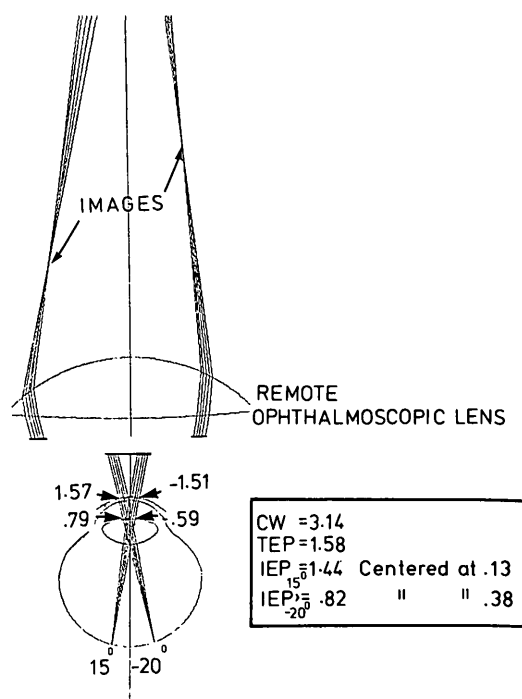

**Fig. 3.** Noncontact system. Camera stop admits only selected rays. In this case a field of  $20^\circ$  is considered. The CW, i.e., the area of the cornea reserved for observation, is  $2 \times 1.57 = 3.14$  mm in diameter. The TEP, i.e., the area occupied by different observation bundles, is  $2 \times 0.79 = 1.58$  mm. The two IEPs are not concentric.

front of the eye (Fig. 1) or a contact lens on the cornea (Fig. 2) forms a very blurred real image of a self-luminous retina. From these illustrations it is clear that no sharp image of any retinal point is formed. It is also evident that, by selecting a smaller aperture for each of the two bundles indicated, one is able to obtain a sharp image of either point (Figs. 3 and 4). In both cases, the pupils for small-field angles are almost concentric. For large-field angles, the pupil for the peripheral bundle may be significantly eccentric.

Let us refer to the individual entrance pupils as IEPs. When the object point scans the retina, the corresponding IEP moves over the pupillary plane of the eye. The total entrance pupil (TEP) corresponds to the area of the pupillary plane that is covered by the moving IEP. The TEP in Fig. 4 is larger than that in Fig. 3 because of the extreme peripheral IEP for the retinal object point at

$85^\circ$  ( $5^\circ$  below the equator, nodal field  $127^\circ$ ).

The TEP has often been considered an optical image of the camera entrance pupil. In general, this is not true in a wide-angle system, where there is no point-to-point correspondence between them. Not all the rays originating from a given retinal point and crossing the TEP are accepted by the recording camera stop. However, no other rays can enter the recording camera stop, so that the TEP is a window for the observation bundles rather than a pupil.

Anterior to the pupillary plane is a common waist of all bundles crossing the TEP (Fig. 5). This waist may eventually be located on the pupillary plane and ideally can become a sharp image of the camera entrance pupil when all the IEPs are equal and concentric. In this ideal case, each IEP equals the TEP. In such a case, from each retinal point in the field of view, there is one ray (the limiting ray of the corresponding bundle) that passes by a point on the edge of the TEP and hits the corresponding point on the edge of the camera stop. Then there will be point-to-point correspondence between the stop and the TEP.

In the next section it will be shown that this is possible only for small-field angles (up to about  $60^\circ$  from the center of the globe) and widely dilated pupils, or for transillumination—illumination through the sclera.

With small IEPs (1 to 1.5 mm are typical of fundus photography) the image-forming bundles for individual retinal points are narrow and remain narrow until they reach the optics of the recording camera, where they uniformly fill the camera diaphragm (Fig. 6). Each bundle uses only a small portion of the refractive surfaces in the system, so that the geometrical aberrations are negligible in those bundles. The aerial image is thus sharp, and the total retinal image (locus of individual images) is diffraction-limited, although the system has not been corrected for that purpose. It is also remarkable that each aerial image point acts, with regard to the camera, as an ordinary object point in air, filling its stop diaphragm completely and uniformly.

From this it follows that in fundus photog-

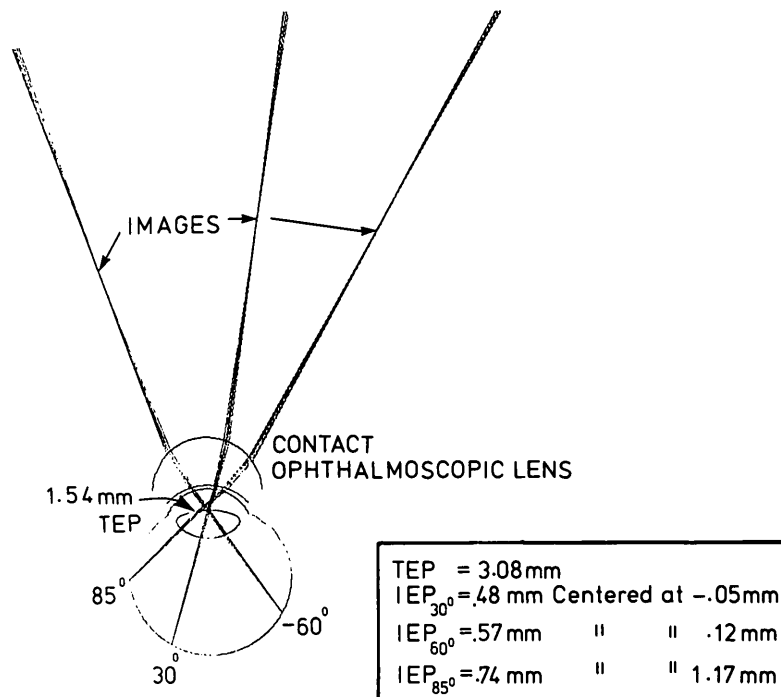

Fig. 4. Contact system. Same situation as described in Fig. 3. It is remarkable that the decentering of IEPs remains small until 60° (measured from the center of the globe) and jumps to more than 1 mm beyond that point.

raphy, as well as in ophthalmoscopy, the free parameters of the contact lens and of the field lens may be reserved for selecting IEPs appropriate to the different retinal points and for directing into the camera optics the ray bundles they define.

#### Curvature of the aerial image

The curvature of the aerial image remains a relevant aberration of the whole lens. A level of illumination comfortable for the patient demands that the camera objective be as fast as possible. A large aperture with correspondingly small depth of field requires that the ophthalmoscopic lens focus both paraxial and peripheral fields in the same plane, despite the severe curvature of the object—the fundus itself. In conventional optical systems, correcting the curvature of the image is not an easy task. It is much simpler in this case. From Figs. 1 to 4 it can be seen that different locations of the IEP will make the corresponding bundle come to a focus at different distances from the ophthalmoscopic

lens. Through appropriate choice of refractive index, thickness, and curvature of the ophthalmoscopic lens and with adequate IEPs for each bundle, it is possible to have all the bundles come to a focus in the same plane (Fig. 5).

From this figure it is clear that to record the entire aerial image formed by these individual images, it is necessary to bend all the bundles into the entrance pupil of the recording camera. This is done by designing an appropriate field lens. Placed between the patient's pupillary plane and the entrance pupil of the recording camera, the field lens, together with the ophthalmoscopic lens, determines the IEPs for any camera stop diaphragm. Since these IEPs have already been chosen so as to flatten the aerial image, the design of the field lens must make them match the selected camera stop (Fig. 7). A small readjustment of IEPs may be needed after the recording camera optics are designed, to keep the film-plane image flat.

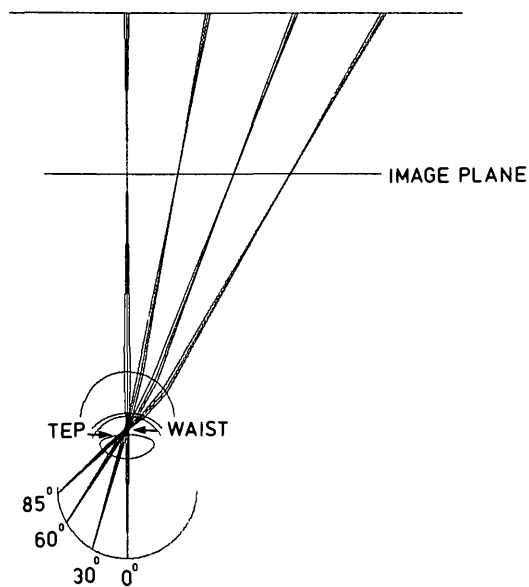

Fig. 5. By the selection of adequate IEPs, the images of the retinal points can be made coplanar.

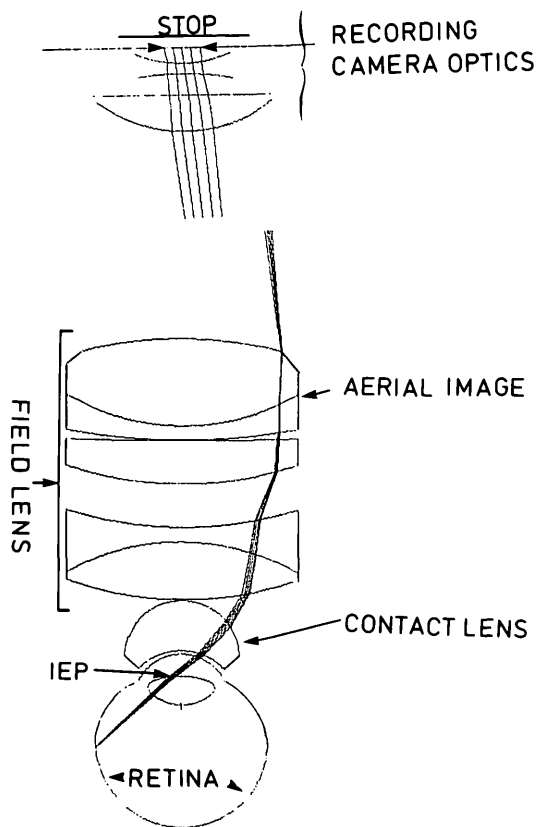

Fig. 6. Rays forming image of corresponding retinal point are uniformly distributed over the stop of the recording camera objective.

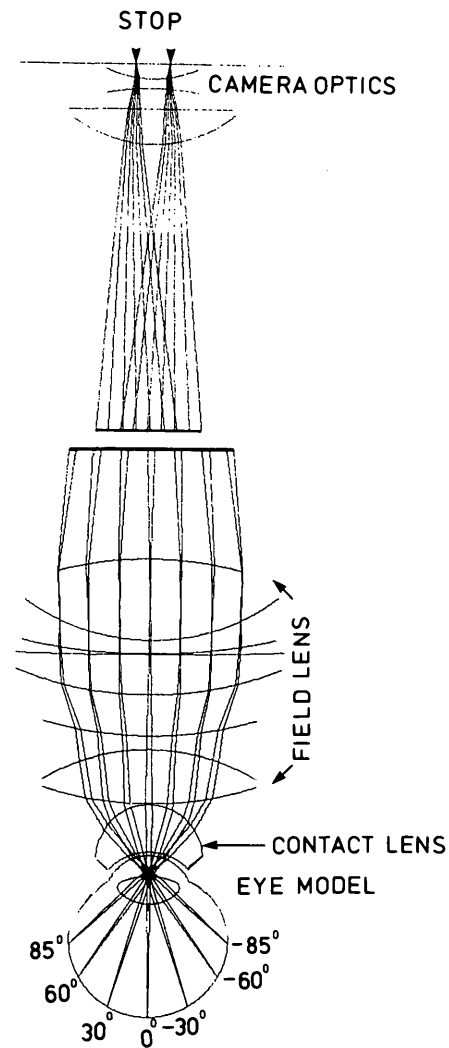

Fig. 7. Entire system including contact lens, field lens, and recording camera optics up to its stop for a field of 170° measured from the center of the globe (125° from the nodal point).

### Illumination of the fundus

The illuminating light used in fundus photography forms a bright, luminous ring on the cornea. This is the image of a light-source diaphragm in noncontact cameras, whereas in a contact camera, it is a ring of optical fiber tips. This light then forms a bright, ring-shaped image on the anterior cortex of the crystalline lens. The dark central areas on the cornea and on the crystalline lens must accommodate the observation window. Let us call CW (corneal window) the diameter of the corneal area that must be reserved for obser-

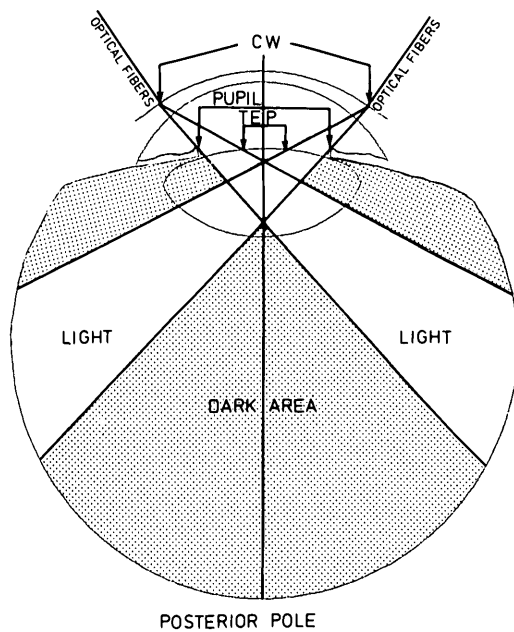

Fig. 8. Situation where no light can reach the posterior pole because the patient's pupil is smaller than the CW, that is, the inner diameter of the ring of fibers is larger than the patient's pupil.

vation (Fig. 8). The corresponding window on the lenticular cortex is the TEP. The outside diameters of the two light rings are the edge of the cornea and the edge of the patient's pupil.

From Fig. 8 we see that the posterior pole is dark unless the patient's pupil is dilated to at least the size of the CW. So, if the patient's pupil is small, the corneal window must also be small.

Fig. 9 shows that the illumination of the periphery poses another constraint, on the TEP this time. The light that starts at some point on the cornea outside the corneal window must reach the retinal periphery while crossing the patient's pupil outside the TEP. This light will, of course, illuminate less of the peripheral retina if the TEP is large.

These two constraints, the imposed pupillary size of the patient's eye (which limits the CW) and the peripheral extent of the field to be photographed (which limits the TEP), critically determine the IEP for the marginal bundle. Fig. 10 shows a plot of rays that originate at a marginal point of the field (in

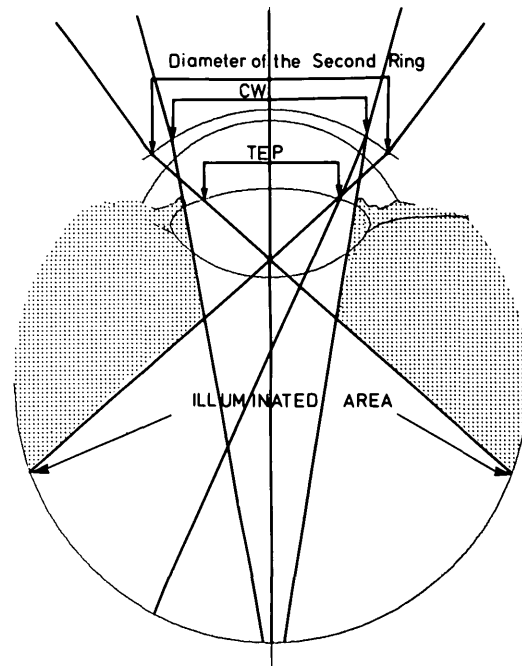

Fig. 9. If the TEP, i.e., the area of the first surface of the crystalline lens cleared for observation, is too large, no light can reach the periphery even when the second ring of fibers is placed at the very periphery of the cornea.

this case,  $85^\circ$ ,  $5^\circ$  below the equator) and pass through an 8 mm pupil to a 12 mm cornea. These rays, internal to the patient's eye, cannot be affected by the designer. Let us assume that the patient's pupil can be dilated to a maximum diameter of 6 mm. The corresponding CW cannot be larger than 6 mm. Therefore the last ray (*PM*) that can be accepted is that which emerges from the cornea at 3 mm from the axis (Fig. 10). The opposite limiting ray (*PN*) from the same retinal point crosses the crystalline lens surface at 1.7 mm from the axis. The limiting ray from the more peripheral optical fibers crosses the crystalline lens at the same point, 1.7 mm from the axis, and reaches the retina slightly anterior to the peripheral point at  $85^\circ$ , thus illuminating a  $127^\circ$  field from the nodal point. Therefore TEP is fixed at 3.4 mm, and *PN* is the other limiting ray of the bundle starting from *P*. This bundle is plotted in Fig. 11 with its pupil of 0.84 mm eccentric by 1.24 mm. This marginal IEP determines the size of the TEP, all other IEPs being more central.

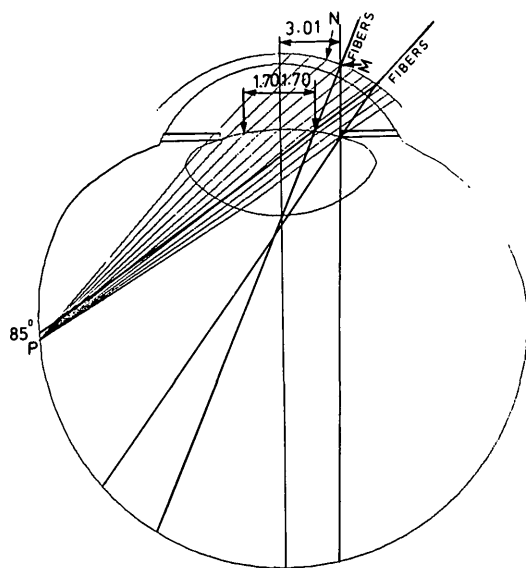

Fig. 10. Ten rays have been traced from the marginal point of the field ( $85^\circ$ ) through an 8 mm pupil. If the CW is to be limited at 6 mm in diameter, ray *PM* is the limiting ray of the admissible bundle. In the same way, TEP (of 140 mm) limits that bundle on the other side by ray *PN*.

#### Design procedure

The marginal bundle determined by the choices of patient's pupil and extent of the field of view constitute the starting point of design. If the CW is to be kept small (when the patient's pupil is small), the corresponding TEP increases rapidly when the field expands beyond  $60^\circ$ . This is half the field angle from the center of the globe and corresponds to an  $80^\circ$  field from the nodal point. Therefore illumination of large fields requires large pupillary dilation. If the illumination traverses the sclera rather than the cornea and the crystalline lens, the CW is limited only by the size of the cornea. In this case, even for the marginal bundle of a large field, we may select a small, central IEP. Thus a large field can be photographed through a very small, undilated pupil (2 mm). This technique (transillumination) is currently used on glaucoma patients and on patients with intraocular lenses. Its use is limited to patients with pale to moderately pigmented fundi.

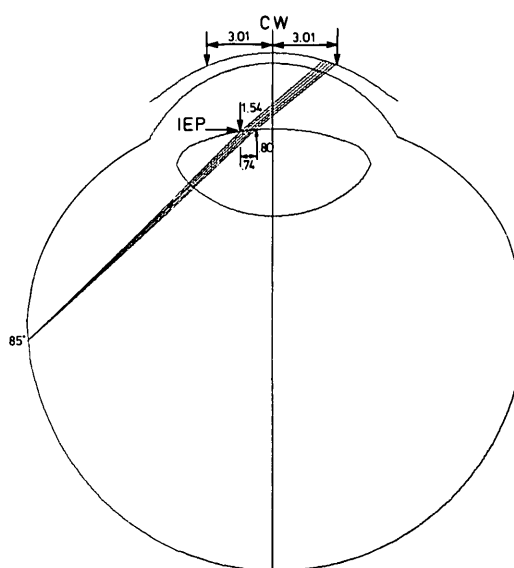

Fig. 11. Bundle of 6 rays limited by aperture, as described in Fig. 10.

#### Conclusions

Design of optical systems for fundus photography and ophthalmoscopy centers on proper manipulation of small, aberration-free bundles of rays from each retinal object point. If the designer uses the free parameters (index, curvature) of the ophthalmoscopic lens system to assure correspondence of the selected IEPs to the recording camera stop (or the observer's pupil), then it is possible to achieve a flat image at the film plane and to follow Gullstrand's principle of separating the apertures used for illumination and observation at both corneal and anterior lens surfaces.

We have developed a terminology for the various relevant apertures, which allows illustration of these points with specific design examples from the EPC.

Editorial assistance was provided by S. Flavia Blackwell.

#### REFERENCES

1. Gullstrand, A.: Einführung in die Methoden der Dioptrik des Auges des Menschen, Leipzig, 1911, S. Hirzel, p. 90.
2. Pomerantzeff, O., and Govignon, J.: Design of a

- wide-angle ophthalmoscope, *Arch. Ophthalmol.* **86**: 420, 1971.
3. Pomerantzeff, O.: Equator-plus camera, *INVEST. OPHTHALMOL.* **14**:401, 1975.
  4. Pomerantzeff, O., Govignon, J., and Schepens, C.L. :  
Wide angle optical model of the human eye, *Ann. Ophthalmol.* **3**:815, 1971.
  5. Pomerantzeff, O., Fish, H., Govignon, J., and Schepens, C.L.: Wide-angle optical model of the eye, *Optica Acta* **19**:387, 1972.

#### **Information for authors**

Most of the provisions of the Copyright Act of 1976 became effective on January 1, 1978. Therefore, all manuscripts must be accompanied by the following written statement, signed by one author: "The undersigned author transfers all copyright ownership of the manuscript (title of article) to The Association for Research in Vision and Ophthalmology, Inc., in the event the work is published. The undersigned author warrants that the article is original, is not under consideration by another journal, and has not been previously published. I sign for and accept responsibility for releasing this material on behalf of any and all co-authors." Authors will be consulted, when possible, regarding republication of their material.